

Series H

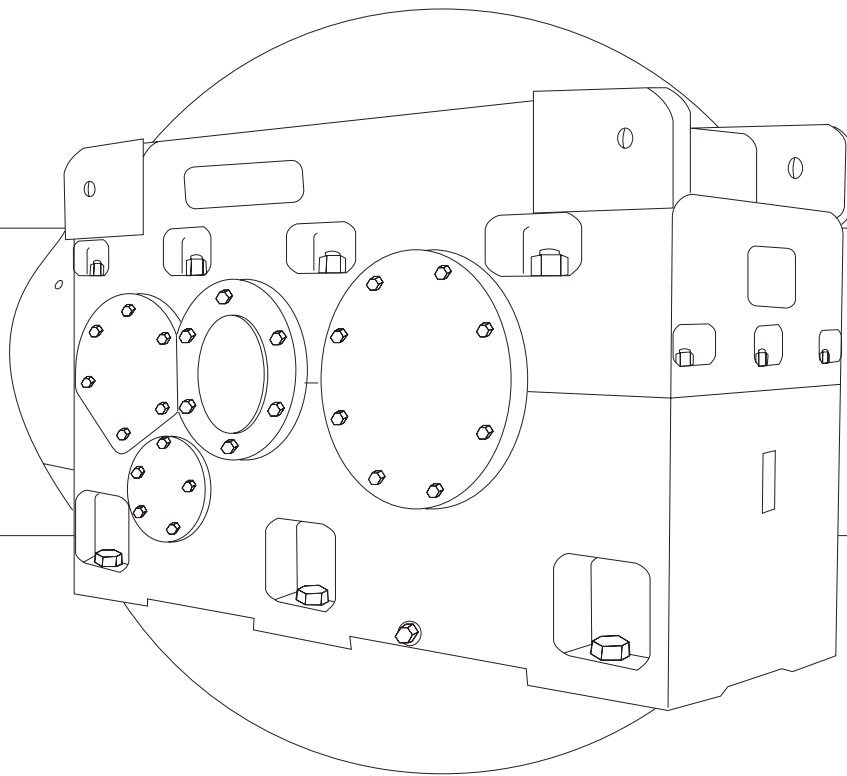

INSTALLATION & MAINTENANCE

IMPORTANT

Product Safety Information

General - The following information is important in ensuring safety. It **must** be brought to the attention of personnel involved in the selection of power transmission equipment, those responsible for the design of the machinery in which it is to be incorporated and those involved in its installation, use and maintenance.

Our equipment will operate safely provided it is selected, installed, used and maintained properly. As with any power transmission equipment **proper precautions must** be taken as indicated in the following paragraphs, to ensure safety.

Potential Hazards - these are **not** necessarily listed in any order of severity as the degree of danger varies in individual circumstances. It is important therefore that the list is studied in its entirety:-

- 1) Fire/Explosion
 - (a) Oil mists and vapour are generated within gear units. It is therefore dangerous to use naked lights in the proximity of gearbox openings, due to the risk of fire or explosion.
 - (b) In the event of fire or serious overheating (over 300 °C), certain materials (rubber, plastics, etc.) may decompose and produce fumes. Care should be taken to avoid exposure to the fumes, and the remains of burned or overheated plastic/rubber materials should be handled with rubber gloves.
- 2) Guards - Rotating shafts and couplings must be guarded to eliminate the possibility of physical contact or entanglement of clothing. It should be of rigid construction and firmly secured.
- 3) Noise - High speed gearboxes and gearbox driven machinery may produce noise levels which are damaging to the hearing with prolonged exposure. Ear defenders should be provided for personnel in these circumstances. Reference should be made to the Department of Employment Code of Practice for reducing exposure of employed persons to noise.
- 4) Lifting - Where provided (on larger units) only the lifting points or eyebolts must be used for lifting operations (see maintenance manual or general arrangement drawing for lifting point positions). Failure to use the lifting points provided may result in personal injury and/or damage to the product or surrounding equipment. Keep clear of raised equipment.
- 5) Lubricants and Lubrication
 - (a) Prolonged contact with lubricants can be detrimental to the skin. The manufacturer's instruction must be followed when handling lubricants.
 - (b) The lubrication status of the equipment must be checked before commissioning. Read and carry out all instructions on the lubricant plate and in the installation and maintenance literature. Heed all warning tags. Failure to do so could result in mechanical damage and in extreme cases risk of injury to personnel.
- 6) Electrical Equipment - Observe hazard warnings on electrical equipment and isolate power before working on the gearbox or associated equipment, in order to prevent the machinery being started.
- 7) Installation, Maintenance and Storage
 - (a) In the event that equipment is to be held in storage, for a period exceeding 6 months, prior to installation or commissioning, we must be consulted regarding special preservation requirements. Unless otherwise agreed, equipment must be stored in a building protected from extremes of temperature and humidity to prevent deterioration.

The rotating components (gears and shafts) must be turned a few revolutions once a month (to prevent bearings brinelling).
 - (b) External gearbox components may be supplied with preservative materials applied, in the form of a "waxed" tape overwrap or wax film preservative. Gloves should be worn when removing these materials. The former can be removed manually, the latter using white spirit as a solvent.

Preservatives applied to the internal parts of the gear units do not require removal prior to operation.
 - (c) Installation must be performed in accordance with the manufacturer's instructions and be undertaken by suitably qualified personnel.
 - (d) Before working on a gearbox or associated equipment, ensure that the load has been removed from the system to eliminate the possibility of any movement of the machinery and isolate power supply. Where necessary, provide mechanical means to ensure the machinery cannot move or rotate. Ensure removal of such devices after work is complete.
 - (e) Ensure the proper maintenance of gearboxes in operation. Use only the correct tools and our approved spare parts for repair and maintenance. Consult the Maintenance Manual before dismantling or performing maintenance work.
- 8) Hot Surfaces and Lubricants
 - (a) During operation, gear units may become sufficiently hot to cause skin burns. Care must be taken to avoid accidental contact.
 - (b) After extended running the lubricant in gear units and lubrication systems may reach temperatures sufficient to cause burns. Allow equipment to cool before servicing or performing adjustments.
- 9) Selection and Design
 - (a) Where gear units provide a backstop facility, ensure that back-up systems are provided if failure of the backstop device would endanger personnel or result in damage.
 - (b) The driving and driven equipment must be correctly selected to ensure that the complete machinery installation will perform satisfactorily, avoiding system critical speeds, system torsional vibration, etc.
 - (c) The equipment must not be operated in an environment or at speeds, powers, torques or with external loads beyond those for which it was designed.
 - (d) As improvements in design are being made continually the contents of this catalogue are not to be regarded as binding in detail, and drawings and capacities are subject to alterations without notice.

The above guidance is based on the current state of knowledge and our best assessment of the potential hazards in the operation of the gear units. Any further information or clarification required may be obtained by contacting our Application Engineers.

SERIES H	
Order No	
Set No	
Unit Type	
Ratio	
Input Speed	
Noise Level @ 1m	* dB(A)

* The noise level will be obtained from the production test

SERIES H

CONTENTS

0108

SECTION	DESCRIPTION	PAGE No
1	Unit Identification _____	4
2	General Information _____	5
3	Fitting of Components to Shafts _____	5
4	Protection of Unit _____	5
5	Installation	
5.1	Motorised and Reducers _____	6
5.2	Fixing to Customers Equipment _____	6
5.3	Motor Connections _____	6
5.4	Foot Mounted Units _____	6
5.5	Shaft Mounted Units / Torque Arm Fixing _____	7 - 9
5.6	Replacement of Oil Seals _____	9
5.7	Holdbacks _____	9
6	Lubrication and Maintenance	
6.1	Lubrication _____	10
6.2	Periodic Inspection _____	10
6.3	Lubricant Changes _____	10
6.4	Lubricant Quantity _____	10
6.5	Approved Lubricants _____	10
6.6	Approved Greases _____	10
7	Cleaning _____	10
APPENDIX		
1	Cooling Coils _____	11
2	Lubricant Quantity and Approved Lubricants _____	12 - 14
3	Approved Bearing Greases _____	15
4	Shaft Alignment _____	16 - 17
5	Bearings _____	18 - 19
6	Tightening Torques for Case Joint Studs, Cover and Housing Bolts _____	20
7	Gears _____	21

UNIT DESIGNATIONS & ORDERING

0108

1 UNIT IDENTIFICATION

When requesting further information, or service support quote the following information from the nameplate:

- Unit Type
- Order Number

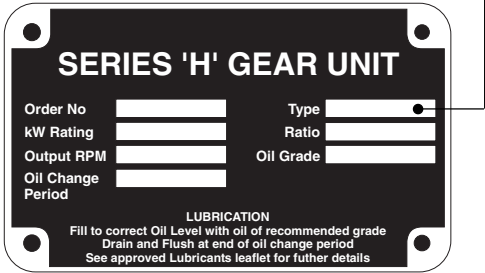
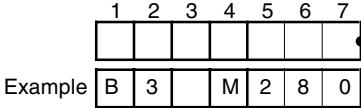

1 - TYPE OF GEARS

- H - HELICAL GEARS ONLY
- B - HELICAL & BEVEL HELICAL GEARS

2 - NO OF REDUCTIONS

- 1 THROUGH 4

3 - UNIT VERSION

- FOOT MOUNTED
- S - SHAFT MOUNTED
- SF - FOOT/SHAFT MOUNTED

5,6,7 - SIZE OF UNIT

- 1 4 0 THROUGH 8 0 0

4 - TYPE OF UNIT

- REDUCER UNIT
- M - MOTORISED

INFORMATION REQUIRED WHEN ORDERING UNITS

PRIME MOVER

- Type - electric motor or engine, for example 4 cylinder internal combustion engine
- Power rating in kW
- Output speed. if variable, indicate speed range and frequency of variation
- Dimensions of prime mover
- Are bedplate and/or couplings required

DRIVEN MACHINE

- Type, for example, stirrer, cooling tower, fan, etc
- Power rating in kW
- Speed
- Service - hours per day, running time in any hour, details of reversals if applicable, type of loading, ambient temperature etc

GEAR UNIT

- Type, for example, VB3
- Size, for example, 400
- Ratio
- Shaft handing. Refer to dimension pages in the catalogue and quote reference
- Direction of rotation (For units with right angle shafts refer to handling diagrams on dimension pages)

SHAFT CONNECTIONS

- Couplings. Quote shaft diameters with tolerances or coupling bores
- Details of overhung loads, including diameter and type of pulley, sprocket or pinion, axial thrust loads and bending moments applied to the outputshafts

ANY ADDITIONAL INFORMATION

--

SERIES H

INSTALLATION AND MAINTENANCE

0108

2 GENERAL INFORMATION

The following instructions will help you achieve a satisfactory installation of your Series H unit, ensuring the best possible conditions for a long and trouble free operation.

All units are tested and checked prior to despatch, a great deal of care is taken in packing and shipping arrangements to ensure that the unit arrives at the customer in the approved condition.

Warning: Both foot and shaft mounted units are designed to operate in the horizontal position.

Reference must be made to our Application Engineers, with full details, where units are required to operate in an inclined position.

3 FITTING OF COMPONENTS TO EITHER THE UNIT INPUT OR OUTPUT SHAFT

The input or output shaft extension diameter tolerance is to ISO tolerance k6 (for shaft diameter $\leq 50\text{mm}$) and m6 (for shaft diameter $> 50\text{mm}$) and the fitted components should be to ISO tolerance M7 (for bore diameter $\leq 50\text{mm}$) and K7 (for bore diameter $> 50\text{mm}$).

- Items (such as gears, sprockets, couplings etc) should not be hammered onto these shafts since this would damage the shaft support bearings.
- The item should be pushed onto the shaft using a screw jack device fitted into the threaded hole provided in the end of the shaft.
- Items being fitted may be heated to 80/100°C to aid assembly further.

THREADED HOLE DETAILS

UNIT SIZE	TYPE OF UNIT	INPUT SHAFT	OUTPUT SHAFT	TYPE OF UNIT	UNIT SIZE	INPUT SHAFT	OUTPUT SHAFT	
140, 160	H1	M16 x 36 mm deep	M24 x 52 mm deep	H1	500	M36 x 70 mm deep	M56 x 100 mm deep	
	H2, B2	M8 x 20 mm deep		H2	500, 560	M30 x 60 mm deep	M56 x 100 mm deep	
	H3, B3	M6 x 16 mm deep			630, 710	M36 x 70 mm deep		
180	H1	M16 x 36 mm deep	M24 x 52 mm deep	H3	500, 560	M24 x 50 mm deep	M56 x 100 mm deep	
	H2, B2	M16 x 36 mm deep			630, 710, 800	M30 x 60 mm deep		
	H3	M6 x 16 mm deep		H4	500, 560	M20 x 40 mm deep	M56 x 100 mm deep	
	B3	M8 x 20 mm deep			630, 710	M24 x 50 mm deep		
200, 225	H1	M24 x 50 mm deep	M24 x 50 mm deep	B2	500	M30 x 60 mm deep		M56 x 100 mm deep
	H2, B2	M16 x 32 mm deep			B3	500, 560	M24 x 50 mm deep	
	H3, B3	M8 x 18 mm deep				630, 710	M30 x 60 mm deep	
250, 280, 315	H1, H2, B2	M24 x 50 mm deep	M30 x 60 mm deep	B4	500, 560	M20 x 40 mm deep	M56 x 100 mm deep	
	H3, B3	M16 x 32 mm deep			630, 710	M24 x 50 mm deep		
355, 400, 450	H1	M30 x 60 mm deep	M42 x 80 mm deep	B4	800	M30 x 60 mm deep		
	H2, H3, B2, B3	M24 x 50 mm deep			H2	500, 560	M20 x 40 mm deep	
						630, 710	M24 x 50 mm deep	
				800	M30 x 60 mm deep			

4 WEATHER PROTECTION OF UNIT

All units prior to despatch are test run with a rust preventative oil giving adequate protection to internal parts for a period of six months covering normal transport in the UK and overseas and covered storage. When the unit is installed the rust preventative dissolves in the first fill of lubricant without harmful effect.

Shaft extensions and hollow output shafts are protected with a rust inhibitor which is proof against sea water and suitable for under-cover storage up to 12 months.

- Notes:
- 1 Where gear units are to operate in abnormal conditions, or where they are to stand for long periods without running, eg in plant installation, our Application Engineers must be notified so that suitable protective arrangements can be made.
 - 2 Gear units which are commissioned and then left standing for an extended period should be operated loaded or unloaded for a short time every two weeks to circulate the lubricant to protect surfaces. If this is not possible the unit should be protected from corrosion.

SERIES H

INSTALLATION AND MAINTENANCE

0108

5 INSTALLATION

5.1 MOTORISED AND REDUCERS

 **WARNING:** The customer shall be responsible for the proper use of articles supplied by the company, particularly the rotating shafts between their driving and driven members, and their guarding for safety, and the company shall not be responsible for any injury or damage sustained as a result of the improper use of the articles supplied. Attention is hereby drawn to the danger of using naked lights in proximity to openings in gearboxes and gear units supplied by the company, and the company shall not be liable for any claim for injury or damage arising from any action in contravention of this warning.

WARNING: All units and couplings are despatched without oil or grease, on installing the unit fill with recommended lubricant to correct level.

NOTE: If lubricant is to be added later then it is important that the same oil is used as is already in the unit.

If an oil other than that in the unit is to be used the unit should be drained and flushed with the oil to be used and filled with the correct quantity.

5.2 FIXING TO CUSTOMER EQUIPMENT

Fixing the feet/pads to customer equipment use set screws to ISO grade 8.8 minimum.

Torque tighten to:-

Set Screw Size	Tightening Torque
M12	85 Nm
M16	200 Nm
M20	350 Nm
M24	610 Nm
M30	1220 Nm
M36	2150 Nm
M42	3460 Nm

5.3 MOTOR CONNECTIONS

TO MAINS

Connection of the electric motor to the mains supply should be made by a qualified person. The current rating of the motor will be identified on the motor plate, and correct sizing of the cables to electrical regulations is essential.

5.4 FOOT-MOUNTED UNITS

The following procedure is recommended for all foot mounted units.

Foot mounted units are supplied either as free standing units, or if required, mounted on a standard baseplate with a foot mounted motor correctly aligned and connected by a flexible coupling.

- Clean shaft extensions and ventilator when fitted.
- Secure unit, or baseplate if fitted to a rigid foundation using heavy duty bolts to ISO grade 8.8 minimum.
- Ensure baseplate is not distorted
Note: Units not supplied on baseplates should if possible be mounted on the same bedplate as the prime mover.
- Align unit (see Appendix 4)
Note: It is important to ensure when aligning unit on baseplate that all machined mounting points are supported over their full area.
If steel packings are used these should be placed either side of the foundation bolt as close as possible. During the final bolting ensure the unit or baseplate is not distorted this will cause strains in the gear case resulting in errors of alignment of shafts and gearing.
- For units mounted on bedplates after alignment select any two diagonally opposite feet, drill ream and dowel in position.
- Fit guards in accordance with the factory acts.
- Check motor wiring for correct direction of rotation this is important when a holdback device is fitted.
- Fill gear unit with oil (if not factory filled) as detailed in Section 6.

SERIES H

INSTALLATION AND MAINTENANCE

0108

5.5 SHAFT MOUNTED UNITS

The following procedure is recommended for all shaft and foot/shaft mounted units.

- a) Clean shaft extensions, bore and ventilator when fitted.
- b) Locate in position, ensuring it is as close as possible to the bearing on the driven machine.
- c) Secure unit onto the shaft.
- d) Fit torque arm to the side of the unit adjacent to the driven machine where possible, as detailed below.

Note: Unless specified otherwise, the torque arm will be supplied loose.

Note: Torque arms must be secured to the chassis structure in a flexible mounting as indicated within a maximum angle of 30° between the vertical plane and a plane towards the gear unit output shaft as illustrated. See Figures 1 and 2

Figure 1

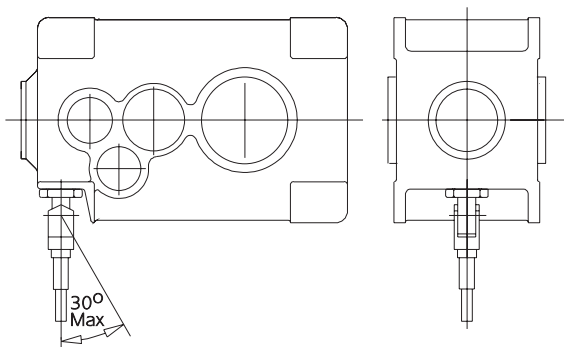
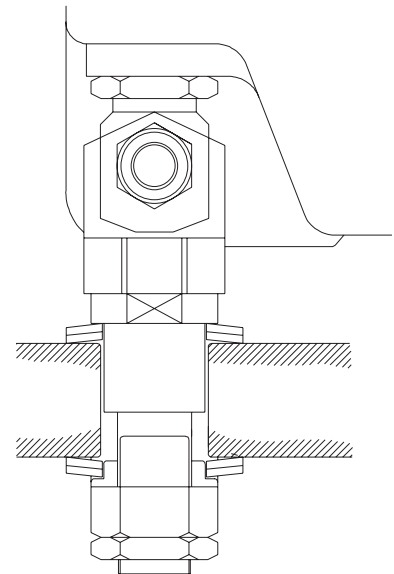

Figure 2



- e) Anchor case to a secure point by means of the torque arm.
- f) Fit guards in accordance with the factory acts.
- g) Check motor wiring for correct direction of rotation, this is important when a holdback device is fitted.
- h) Fill gear unit with oil (if not factory filled) as detailed in Section 6.

KEY DRIVE (SIZES 140 & 160)

All types of shaft mounted units sizes 140 and 160 are supplied suitable for mounting on shafts fitted with keys.

Recommended Shaft Dimensions for Driven Machines

UNIT SIZE	SHAFT DETAILS MM	
	DIAMETER *	LENGTH (MIN)
140	75	250
160	85	290

* Tolerances for shaft diameters should be m6

SERIES H

INSTALLATION AND MAINTENANCE

0108

SHRINK DISC DRIVE (SIZES 180 AND ABOVE)

Each shaft mounted gear unit is fitted with a 'shrink disc' device located on the hollow output shaft to provide a positive outer locking connection between gear unit and driven shaft. The 'shrink disc' is a friction device, without keys, which exerts an external clamping force on the hollow output shaft, thus establishing a mechanical shrink fit between the gear unit hollow shaft and driven shaft. 'Shrink disc' capacities have ample margins in dealing with transmitted torques and external loading imposed on gear units.

WORKING PRINCIPLE

The 'shrink disc' consists of two locking collars, a double tapered inner ring, locking screws and a sealing ring. By tightening the locking screws, the locking collars are pulled together, exerting radial forces on the inner ring, thus creating a positive friction connection between hollow shaft and driven shaft (See Figure 1).

As the tapered surfaces of locking collars and inner ring are lubricated with Molykote 321R or similar and the taper angle is not self locking, locking collars will not seize on the inner ring and can be released easily when removal is necessary.

When the shrink disc is clamped in position the high contact pressures between tapered surfaces and screw heads and their seatings ensure hermetic sealing and eliminate the possibility of fretting corrosion.

UNIT SIZE	SHAFT OF DRIVEN MACHINE					
	d*	d1	D*	L1	L2	L3
180	85	87	90	412	332	80
200	95	97	100	437	347	90
225	115	117	120	487	377	110
250	125	127	130	527	407	120
280	140	142	145	580	445	135
315	160	162	165	625	475	150
355	170	172	175	705	540	165
400	190	195	200	795	615	180
450	220	225	230	885	695	190

Refer to our Application Engineers for sizes 500 and above

* Tolerances for shaft diameters D and d are to h6 for diameters 95 to 165 and g6 for 165 and above

Figure 1

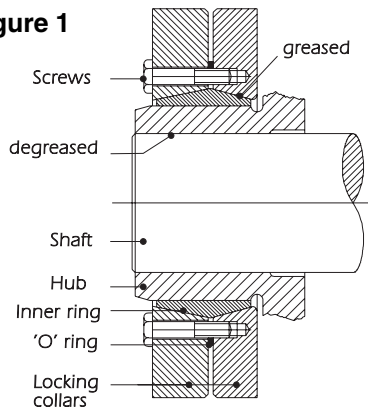
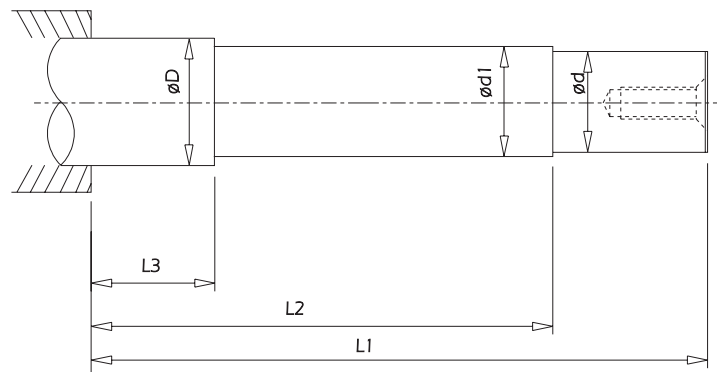

Figure 2



INSTALLATION

'Shrink discs' are supplied with shaft mounted units. The following procedures should be followed when fitting or removing units from the driven shaft.

- 1 Release locking screws gradually and in succession. Initially a quarter of a turn on each screw will avoid tilting and jamming of collars.
- 2 Remove collars and 'shrink disc' thoroughly.
- 3 Clean and degrease locating diameters of gear unit hollow shaft, driven shaft and 'shrink disc' locating diameter on hollow shaft extension.
- 4 Draw the gear unit onto the driven shaft (See Figure 3).
- 5 Grease tapered surfaces of locking collars and inner ring with Molykote 321R or similar.
- 6 Fit 'shrink disc' on gear unit hollow shaft to position shown in Figure 2.
- 7 Tighten all locking screws gradually and in succession. Do not tighten in a diametrically opposite sequence. Several passes are required until all screws are tightened to the torque figures Ma shown in the table opposite in Nm. This is stamped on the inner face of the 'shrink disc'.
- 8 Fit protective cover.
Locking collars must remain equidistant over 360°.

SERIES H

INSTALLATION AND MAINTENANCE

0108

Note: When the hollow output shaft is to operate in a vertical position it is essential that the shaft of the driven machine is provided with a shoulder. When the thrust load is not taken by the shoulder on the driven shaft, a thrust plate, as shown in Figure 1, must be fitted.

It is recommended that customers' shafts at the non-clamped end of the sleeve should be coated with Molykote 321 R or equivalent.

Figure 3

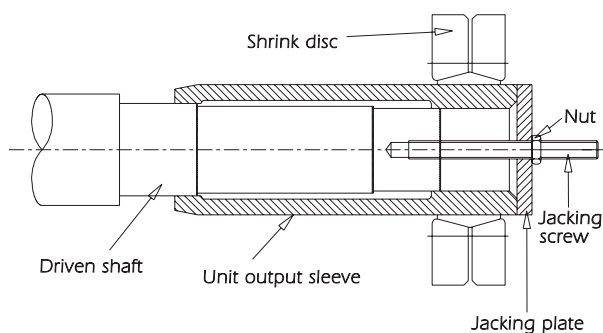
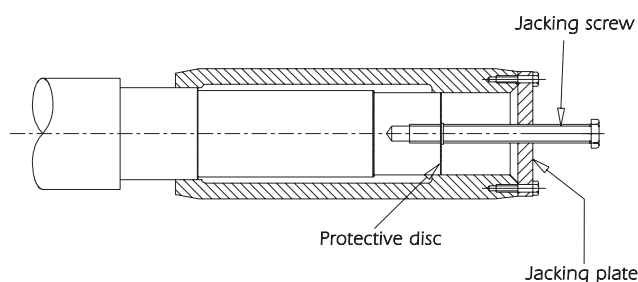

Figure 4



Recommended Tightening Torques (Ma) for Shrink Disc Bolts

Size of unit	180	200	225	250	280	315	355	400	450
Tightening Torque (Nm)	58	58	100	240	240	240	240	470	470

Refer to our Application Engineers for sizes 500 and above

REMOVAL

- 1 Removal procedure is similar to the reverse of installation.
Note: Do not remove 'shrink disc' locking screws completely.
- 2 Remove any rust and dirt from gear unit hollow shaft.
- 3 Withdraw gear unit from driven shaft (See Figure 4).

Note: 'Shrink disc' should be removed and cleaned thoroughly, and Molykote 321 R or similar applied to the tapered surfaces of inner ring and locking collars before re-use. The 'O' ring should be replaced if worn or damaged.

Note: Protective covers are supplied with all 'shrink discs'. Assembly or removal kits and thrust plates are not provided.

5.6 REPLACEMENT OF OIL SEALS

Oilseals should be replaced whenever the unit is dismantled or if in service it shows signs of leakage or damage.

Recommended procedure for replacing an oilseal:-

- 1) Clean and drain unit
- 2) Remove any parts that may obstruct access to seal (eg fan and cowl).
- 3) Remove bolts and withdraw oil catcher. Take care not to damage the shims and do not alter the shaft position. Check for burrs and scratches on the shaft as these could damage the new seal.
- 4) Tap the old seal out of the housing.
- 5) Clean joint faces and shims.
- 6) Position shims on oil catcher.
- 7) Coat joint faces of oil catcher and gearcase with a good jointing compound.
- 8) Replace oil catcher and tighten bolts to the values shown in the table.
- 9) Fit replacement seal. Protect seal lips by wrapping shaft with thin strong paper coated in oil or grease, then using appropriate sized drift press into housing. For best performance ensure that the seal is seated square with the shaft.
- 10) Fill unit with a recommended lubricant to correct level as indicated on dipstick.

5.7 REPLACEMENT OF HOLDBACKS

If and when it becomes necessary to replace the holdback contact us.

SERIES H

INSTALLATION AND MAINTENANCE

0108

6 LUBRICATION AND MAINTENANCE

6.1 LUBRICATION

All Series H units are despatched without oil and therefore filled by the client. The grade and type of oil will be stamped on the nameplate in accordance with either of the types of oil from Tables 2 or 3 in Appendix 2.

The approximate quantity of oil required is given in Table 1, Appendix 2 and the unit filled to the level marked on the dipstick.

Warning Do not overfill the unit as this can cause leakage and overheating.

Where possible run the unit without load for a short time to circulate the lubricant thoroughly, then stop the unit and re-check the oil level after allowing the unit to stand for 10 minutes and if necessary top up to the correct mark on the dipstick.

(NB For units fitted with a holdback device refer to our Application Engineers for recommended lubricant)

6.2 PERIODIC INSPECTION

Check oil level every 1000 hours or 2 months whichever is sooner, and if necessary top up with the recommended grade of lubricant.

6.3 OIL / GREASE CHANGES

On all sizes regular oil changes are essential and the following factors should be used to determine the frequency at which these are carried out.

- a. Oil temperature - unit operating under load.
- b. Type of oil.
- c. Environment - humidity, dust, etc.
- d. Operating conditions - shock, loading, etc.

At elevated temperatures the effective life of the oil is very much reduced. This is most pronounced with oils containing fatty and E.P. additives. To prevent damage to the unit through lubricant breakdown the oil should be renewed as detailed in the following table:

UNIT OPERATING TEMPERATURE °C	RENEWAL PERIOD					
	MINERAL OIL			SYNTHETIC OIL		
75 OR LESS	17000 HOURS	or	3 YEARS	26000 HOURS	or	3 YEARS
80	12000 HOURS	or	3 YEARS	26000 HOURS	or	3 YEARS
85	8500 HOURS	or	3 YEARS	21000 HOURS	or	3 YEARS
90	6000 HOURS	or	2 YEARS	15000 HOURS	or	3 YEARS
95	4200 HOURS	or	17 MONTHS	10500 HOURS	or	3 YEARS
100	3000 HOURS	or	12 MONTHS	7500 HOURS	or	2.5 YEARS
105	2100 HOURS	or	8 MONTHS	6200 HOURS	or	2 YEARS
110	1500 HOURS	or	6 MONTHS	5200 HOURS	or	18 MONTHS

NB: INITIAL FILL OF OIL SHOULD BE CHANGED IN A NEW GEAR UNIT AFTER 1000 HOURS OPERATION OR ONE YEAR OR HALF THE ABOVE LIFE WHICHEVER IS THE SOONEST

Note:

Figures quoted are for oil temperatures when the unit has attained normal running temperature when operating under load. These figures are based on normal running but where conditions are particularly severe it may be necessary to change the oil more frequently. When changing lubricant, if same lubricant is not used then unit must be flushed out and filled only with one type of lubricant.

The procedure for changing an oil should be to drain the oil preferably when hot and after circulation. If the gear unit is to be flushed, the unit should be filled to the appropriate level with an oil of the same viscosity grade and type as the lubricating oil and run before the flushing oil is drained. This procedure should be followed especially if the type of oil is being changed. The unit should be filled with the approved oil to the level marked on the dipstick. Re-check the oil level after a short period of running and top up as necessary. On certain units the outputshaft bearings are grease lubricated, these should be re-greased at 2000 to 3000 hour intervals unless otherwise instructed.

6.4 LUBRICANT QUANTITY

The quantity of lubricant required by size and type is given in Table 1, Appendix 2.

6.5 APPROVED LUBRICANTS

Tables 2 and 3 Appendix 2 give the lubricants approved for use in the gear unit.

6.6 APPROVED GREASES

Appendix 3 gives the greases approved for use in the unit.

7 CLEANING

With the drive stationary periodically clean any dirt or dust from the gear unit and the electric motor cooling fins and fan guard to aid cooling.

COOLING COIL

If required, units will be supplied with a cooling coil fitted with enough pipe protruding to allow connection to customers pipe work via a suitable straight coupling.

The coils fitted are suitable for fresh, brackish or sea water with flow in either direction. Connections are therefore interchangeable.

Note: Cooling coils are not available on shaft mounted units types H2S, H3S, B2S and B3S.
Cooling coils cannot be fitted to vertical units.

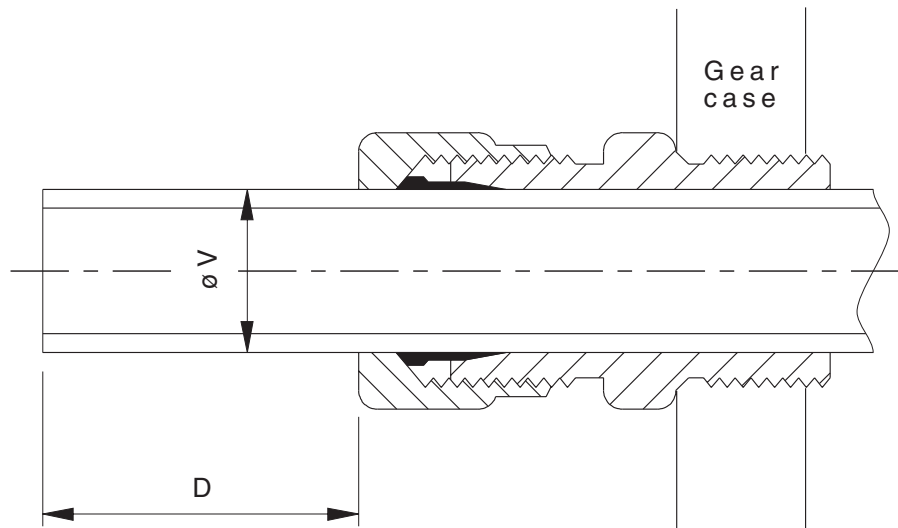

UNIT SIZE	øV Copper tube diameter	D
140, 160, 180	10 mm	50 mm
200 to 800	12 mm	50 mm

SERIES H

APPENDIX 2

LUBRICATION

0108

All Series H units are despatched without oil and therefore filled by the client. The grade and type of oil will be stamped on the nameplate in accordance with either of the types of oil from tables 2 or 3. The oil change period will be as stated in section 6 on page 10.

The approximate quantity of oil required is given in Table 1, but the unit should always be filled to the level marked on the dipstick. Warning: Do not overfill the unit as this can cause leakage and overheating.

Where possible run the unit without load for a short time to circulate the lubricant thoroughly, then stop the unit and recheck the oil level after allowing the unit to stand for 10 minutes and if necessary top up to the correct mark on the dipstick.

In addition where bearings are grease packed, the greases approved are given in Appendix 3.

TABLE 1 LUBRICANT QUANTITY (Litres)

Unit Type	UNIT SIZE															
	140	160	180	200	225	250	280	315	355	400	450	500	560	630	710	800
H1	6	9	13	18	25	35	45	70	95	130	180	245	-	-	-	-
H2	7	11	15	20	27	35	50	70	100	140	205	320	425	650	895	-
H2SF	7	11	15	20	27	35	50	70	100	140	205	320	425	650	895	-
H2S	-	-	-	19	25	32	45	55	90	125	175	230	290	435	655	-
VH2	-	-	-	21	29	40	55	76	105	150	210					
VH2SA	-	-	-	21	29	40	55	76	105	150	210					
VH2CT	-	-	-	21	29	40	55	76	105	150	210					
H3	9	13	17	20	27	35	50	70	100	140	205	415	550	825	1150	1580
H3SF	9	13	17	20	27	35	50	70	100	140	205	415	550	825	1150	1580
H3S	-	-	-	19	25	32	45	55	90	125	175	315	405	585	870	1230
VH3	-	-	-	21	29	40	55	76	105	150	210					
VH3SA	-	-	-	21	29	40	55	76	105	150	210					
VH3CT	-	-	-	21	29	40	55	76	105	150	210					
H4	9	13	17									415	550	825	1150	1580
H4SF	9	13	17									415	550	825	1150	1580
B2	6	9	13	18	25	35	45	70	95	130	180	275	-	-	-	-
B2SF	6	9	13	18	25	35	45	70	95	130	180	275	-	-	-	-
B2S	-	-	-	17	22	30	40	50	80	115	165	190	-	-	-	-
VB2	-	-	-	18	25	34	47	65	92	130	180					
VB2SA	-	-	-	18	25	34	47	65	92	130	180					
VB2CT	-	-	-	18	25	34	47	65	92	130	180					
B3	7	11	15	20	27	35	50	70	100	140	205	410	535	800	1095	-
B3SF	7	11	15	20	27	35	50	70	100	140	205	410	535	800	1095	-
B3S	-	-	-	19	25	32	45	55	90	125	175	315	405	575	835	-
VB3	-	-	-	21	29	40	55	76	105	150	210					
VB3SA	-	-	-	21	29	40	55	76	105	150	210					
VB3CT	-	-	-	21	29	40	55	76	105	150	210					
B4	9	13	17									510	670	1000	1390	1920
B4SF	9	13	17									510	670	1000	1390	1920

Please refer to our Application Engineers for capacities not shown

SERIES H

APPENDIX 2

APPROVED LUBRICATION

0108

TABLE 2 APPROVED LUBRICANTS

Type E Mineral oil containing industrial EP additives. These have a high load carrying capacity

SUPPLIER	LUBRICANT RANGE	See notes page 14	GRADE NUMBERS		
			5E	6E	7E
			AMBIENT TEMPERATURE RANGE °C		
			-5 to 25	0 to 40	10 to 50
Batoyle Freedom Group	Remus	b	220 (-2)	320 (-2)	460 (-2)
Boxer Services / Millers Oils	Indus	b,e	220 (-10)	320 (-10)	460 (-10)
BP Oil International Limited	Energol GR-XF	b,c,e	220 (-16)	320 (-13)	460 (-1)
	Energol GR-XP	b,e	220 (-15)	320 (-10)	460 (-7)
Caltex	Meropa	b	220 (-4)	320 (-4)	460 (-4)
	RPM Borate EP Lubricant	b	220 (-7)	320 (-4)	460 (-7)
Carl Bechem GmbH	Berugear GS BM	b	220 (-20)	320 (-13)	460 (-10)
	Staroil G	b	220 (-13)	320 (-13)	460 (-10)
Castrol International	Alpha Max	b,c,e	220 (-19)	320 (-13)	460 (-10)
	Alpha SP	b,e	220 (-16)	320 (-16)	460 (-1)
Chevron Lubricants	Gear Comp EP (USA ver)	b	220 (-16)	320 (-13)	460 (-10)
	Gear CompEP (Eastern ver)	b	220 (-13)	320 (-13)	460 (-13)
	Ultra Gear	b	220 (-10)	320 (-7)	460 (-7)
Eko-Elda Abee	Eko Gearlub	b	220 (-13)	320 (-10)	460 (-1)
Engen Petroleum Limited	Gengear	b	220 (-13)	320 (-10)	460 (-1)
Esso	Spartan EP	b,c	220 (-16)	320 (-13)	460 (-7)
Esso/Exxon	Spartan EP	b,h	220 (-12)	320 (-12)	460 (-4)
Fuchs Lubricants	Powergear	b		P/Gear (-16)	M460 (-4)
	Renogear V	b	220EP (-13)	320EP (-4)	460EP (-4)
	Renogear WE	b	220 (-7)	320 (-4)	400 (-4)
	Renolin CLPF Super	b,d,e	6 (-13)	8 (-10)	10 (-10)
Klüber Lubrication	Klüberoil GEM1	b	220 (-5)	320 (-5)	460 (-5)
Kuwait Petroleum International	Q8 Goya	b	220 (-16)	320 (-13)	460 (-10)
Lubrication Engineers Inc	Almasol Vari-Purpose Gear	b	607 (-18)	605 (-13)	608 (-10)
Mobil Oil Company Limited	Mobil gear 600 Series	b	630 (-13)	632 (-13)	634 (-1)
	Mobil gear XMP	b,c	220 (-19)	320 (-13)	460 (-7)
Omega Manufacturing Division	Omega 690	b,e		85w/140 (-15)	
Optimol Ölwerke GmbH	Optigear BM	b	220 (-11)	320 (-10)	460 (-7)
	Optigear	b	220 (-18)	320 (-9)	460 (-7)
Pertamina (Indonesia)	Masri	b,e	220 (-4)	320 (-4)	460 (-4)
Petro-Canada	Ultima EP	b,e	220 (-22)	320 (-16)	460 (-10)
Rocol	Sapphire Hi-Torque	b,e	220 (-13)	320 (-13)	460 (-13)
Sasol Oil (Pty) Limited	Cobalt	b,e	220 (-4)	320 (-1)	460 (-4)
	Hemat	b,e	220 (-10)	320 (-7)	460 (-4)
Saudi Arabian Lubr. Oil Co.	Gear Lube EP	b,e	EP220 (-1)	EP320 (0)	EP460 (0)
Shell Oils	Omala	b	220 (-4)	320 (-4)	460 (-4)
	Omala F	b,c	220 (-13)	320 (-10)	460 (-4)
Texaco Limited	Meropa	b	220 (-16)	320 (-16)	460 (-10)
	Meropa WM	b, c	220 (-19)	320 (-16)	460 (-11)
Total	Carter EP	b	220 (-7)	320 (-7)	460 (-4)
	Carter VP/CS	b	220 (-16)	320 (-13)	460 (-7)
Tribol GmbH	Molub-Alloy Gear Oil	b,d	90 (-18)	690 (-16)	140 (-13)
	Tribol 1100	b	220 (-20)	320 (-18)	460 (-16)

DANGER

Numbers in brackets indicate recommended minimum operating temperature in °C.
THE UNIT MUST NOT RUN BELOW THIS TEMPERATURE.

SERIES H

APPENDIX 2

APPROVED LUBRICATION

0108

TABLE 3 APPROVED LUBRICANTS

Type H Polyalphaolefin based synthetic lubricants with Anti-Wear or EP additives. These have a medium to high load carrying capacity.

SUPPLIER	LUBRICANT RANGE	See notes	GRADE NUMBERS		
			5H	6H	7H
			AMBIENT TEMPERATURE RANGE °C		
			-10 to 30	0 to 45	10 to 50
Batoyle Freedom Group	Titan	b	220 (-31)	320 (-28)	
Boxer Services / Millers Oils	Silkgear	b	220 (-35)	320 (-35)	460 (-35)
BP Oil International Limited	Enersyn EPX	b,e		320 (-28)	
Caltex	Pinnacle EP	b	220 (-43)	320 (-43)	460 (-37)
Carl Bechem GmbH	Berusynth GP	b	220 (-38)	320 (-35)	460 (-32)
Castrol International	Alphasyn EP	b,c	220 (-37)	320 (-31)	460 (-31)
	Alphasyn T	b	220 (-31)	320 (-28)	460 (-28)
Chevron Lubricants	Tegra	b	220 (-46)	320 (-33)	460 (-31)
Esso/Exxon	Spartan Synthetic EP	b,e	220 (-46)	320 (-43)	460 (-40)
Fuchs Lubricants	Renogear SG	b	220 (-32)	320 (-30)	
Klüber Lubrication	Klübersynth GEM 4	b	220 (-35)	320 (-35)	460 (-30)
Kuwait Petroleum International	Q8 EL Greco	b	220 (-22)	320 (-19)	460 (-16)
Lubrication Engineers Inc	Synolec Gear Lubricant	b	9920 (-40)		
Mobil Oil Company Limited	Mobilgear SHC	b	220 (-40)	320 (-37)	460 (-32)
	Mobilgear SHC XMP	b,c	220 (-40)	320 (-33)	460 (-31)
Optimol Ölwerke GmbH	Optigear Synthetic A	b	220 (-31)	320 (-31)	
Petro-Canada	Super Gear Fluid	b,e	220 (-43)	320 (-37)	460 (-37)
Shell Oils	Omala HD	b,c	220 (-43)	320 (-40)	460 (-37)
Texaco Limited	Pinnacle EP	b	220 (-43)	320 (-43)	460 (-37)
	Pinnacle WM	b,c	220 (-43)	320 (-40)	
Total	Carter SP	b	220 (-34)	320 (-31)	460 (-28)
Tribol GmbH	Tribol 1510	b	220 (-36)	320 (-33)	460 (-28)

- NOTES:**
- b) These lubricants should not be used in units fitted with trailing sprag or holdback devices without prior agreement with the manufacturer; the additives, or the base fluids may modify the coefficient of friction which these devices depend on.
 - c) These lubricants have been tested for micro-pitting (FZG Type C), test results are available.
 - d) These oils contains solid lubricants (eg MOS₂ or graphite) and must NOT be used in units fitted with any type of hold-back device which relies on friction for its operation.
 - e) These lubricants contain additives which may adversely affect silvered or white metal components; consult oil supplier.
 - h) Minimum operating temperatures of these lubricants are based on worst case values, lower operating temperatures may be available, please check with local stockist.

DANGER

Numbers in brackets indicate recommended minimum operating temperature in °C.
THE UNIT MUST NOT RUN BELOW THIS TEMPERATURE.

SUPPLIER	LUBRICANT RANGE	ALLOWABLE OPERATING TEMPERATURE RANGE °C	
		ABOVE	TO
BP Oil International Limited	Energrease LS-EP	-30	130
Caltex	Multifak EP	0	120
Castrol International	LMX Grease	-40	150
	Spheerol AP	-30	110
	Spheerol EPL	-10	120
Fuchs Lubricants	Renolit EP	-25	100
Klüber Lubrication	Klüberlub BE 41-542	-20	140
Mobil Oil Company Limited	Mobilgrease XHP	-15	150
	Mobilith SHC	-20	180
Omega Manufacturing Division	Omega 85	-40	230
Optimol Ölwerke GmbH	Longtime PD	-45	140
Shell Oils	Albida RL	-20	150
	Alvania EP B	-20	120
	Nerita HV	-30	130
Texaco Limited	Multifak All Purpose EP	-30	140

Notes:

- 1) All the above greases are NLGI grade 2.
- 2) Refer to our Application Engineers if the unit is operating in an ambient temperature outside the range of -30°C to 50°C.

SERIES H

APPENDIX 4

SHAFT ALIGNMENT

0108

SHAFT ALIGNMENT

Errors of alignment fall into categories of angularity (see figure 1) and eccentricity (see figure 2), or a combination of both.

Errors of angularity should be checked for and corrected before errors of eccentricity

Alignment in accordance with the following procedure will ensure vibration levels meeting those set out in ISO 10816 Part 1.

Errors of Angularity

If the faces are perfectly true, the angularity can be checked by keeping both shafts stationary and taking measurements with a block gauge and feelers at the four points 1, 2, 3 and 4 as shown in figure 3. The difference between the readings 1 and 3 will give the error of alignment in the vertical plane, over the length of the shaft equal to the diameter of the coupling flanges, and from this the difference in the relative heights of the feet of the motor or other connected machine can be found by proportion. Similarly the difference between the readings 2 and 4 gives the amount of sideways adjustment necessary to correct any errors of alignment in the horizontal plane.

Generally, however, the coupling faces will not be absolutely true and whilst any errors so found could be allowed for in checking angularity by the stationary method an easier method presents itself. This consists in marking the points 1 on both "A" and "B" and rotating both half couplings, keeping the marked points together. By taking measurements each quarter-revolution the errors in the vertical and horizontal planes are again found.

The permitted angularity error is as follows

TYPE OF COUPLING	ALLOWABLE GAP (G) (mm)
Rigid coupling	$G = 0.0005 D$
All other types	Please see appropriate installation and maintenance manual for coupling type fitted

NOTE: D is the diameter (mm) at which the gap is measured.

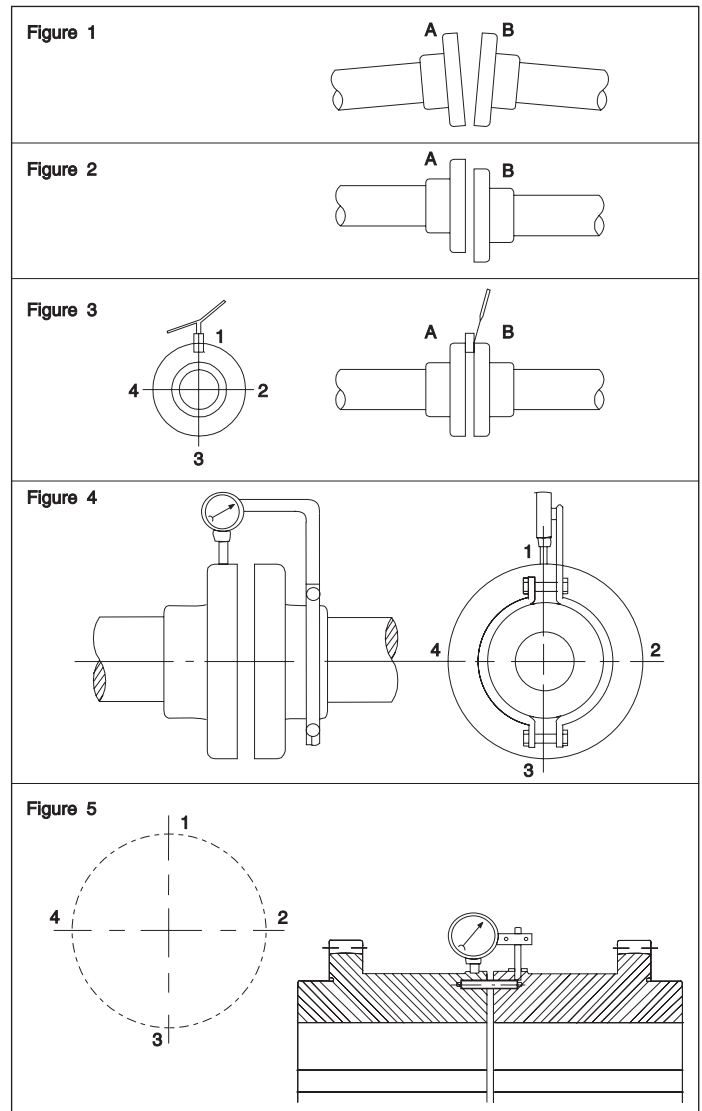

NOTE: Check the alignment after running the unit until it has attained its normal working temperature. Any discrepancies can then be rectified.

SERIES H

APPENDIX 4

SHAFT ALIGNMENT

0108

Errors of Eccentricity

The procedure for measuring eccentricity is precisely analogous to that used for angularity. In this case, however, the measurements are taken in a radial direction and the most convenient and accurate means of doing this utilises a dial indicator suitably clamped to one half coupling, and bearing on the hub or flange of the other, as shown in figures 4 and 5 on page 16.

Care must, however, be taken to ensure the support for the dial indicator is sufficiently rigid to prevent the weight of the indicator from causing deflection and, in consequence, inaccurate readings. Extra care should be taken where taper roller bearings are fitted to ensure that alignment is checked with shafts in mid-point position and a final check made with the unit at operating temperature.

The permitted eccentricity error which can be accommodated in addition to that of the angularity error is as follows :-

i) Input Shaft

As the input power to the unit varies with its overall ratio couplings of various sizes may be fitted to a particular unit.

TYPE OF COUPLING	COUPLING SIZE	ALLOWABLE ECCENTRICITY (mm)
All coupling types	Please see appropriate installation and maintenance manual for coupling type fitted	

ii) Output Shaft

TYPE OF COUPLING	UNIT SIZE	ALLOWABLE ECCENTRICITY (mm)
Rigid	140 to 180	0.050
	200 to 250	0.075
	280 to 355	0.085
	400 to 450	0.100
All other types	Please see appropriate installation and maintenance manual for coupling type fitted	

SPECIAL NOTE CONCERNING RIGID COUPLINGS

In lining up elements involving rigid couplings it is important that no attempt is made to correct errors of alignment or eccentricity greater than those above by tightening of the coupling bolts (This applies when the system is cold or at operating temperature). The result is mis-alignment and the setting up of undue stresses in the shaft, coupling and bearings. This will be revealed by the springing apart of the coupling faces if the bolts are slackened off. A check on the angularity of a pre-assembled job, after bolting down, can be obtained in the case of rigid couplings by slackening off the coupling bolts, when any mis-alignment will cause the coupling faces to spring apart. This check may not, however, reveal any strains due to eccentricity owing to the constant restraint imposed by the spigot.

SERIES X COUPLINGS

We produce standard flexible couplings to cover the complete range of units, please contact us for details.

SERIES H

APPENDIX 5

BEARINGS

0108

BEARINGS

The bearings for the Series H range have all been selected very carefully to best suit the requirements of each unit and to more than adequately deal with the designed maximum loads put upon them. Because of their load carrying ability, roller bearings have been used throughout, depending on the unit type and shafts as to whether taper roller, parallel roller or spherical roller bearings are fitted (see table below for details of which type of bearing are fitted where).

BEARING END FLOAT

If unit is dismantled or partly dismantled on reassembly the bearing end floats should be checked and adjusted as required. The spherical and parallel roller bearings fitted to some shafts require no setting of bearing end float as component tolerances make allowances for it, but they are to be subject to frequent reversals refer to our Application Engineers. The shafts fitted with taper roller bearings however have tighter tolerances of bearing end float and require careful setting.

Two methods of achieving the correct bearing end float on these shafts with taper roller bearings, method one is for all shafts except the bevel input shaft, method two is for bevel input shaft only.

Type of Unit	Shaft	Type of Bearing	Size of Unit							
			140 min/max	160 min/max	180 min/max	200 min/max	225 min/max	250 min/max	280 min/max	315 min/max
H1	Input Shaft	Taper Roller	0.050/0.100	0.050/0.100	0.075/0.125	0.075/0.125	0.075/0.125	0.075/0.125	0.075/0.150	0.075/0.150
	Output Shaft	Spherical Roller	1.000	1.000	1.000	0.250	0.300	0.300	0.340	0.400
H2	Input Shaft	Taper Roller	0.050/0.100	0.050/0.100	0.050/0.100	0.050/0.100	0.050/0.100	0.050/0.100	0.075/0.150	0.075/0.150
	2nd Reduction Pinionshaft	Taper Roller	0.050/0.100	0.050/0.100	-	-	-	-	-	-
		Parallel Roller	-	-	0.170	0.190	0.210	0.230	0.250	0.280
	Output Shaft (foot mounted)	Spherical Roller	1.000	1.000	1.000	0.250	0.300	0.300	0.340	0.400
Output Shaft (shaft mounted)	Parallel Roller	0.140	0.155	0.170	0.190	0.210	0.230	0.250	0.280	
H3	Input Shaft	Taper Roller	0.025/0.075	0.050/0.100	0.050/0.100	0.050/0.100	0.050/0.100	0.050/0.100	0.050/0.100	0.050/0.100
	2nd Reduction Pinionshaft	Taper Roller	0.050/0.100	0.050/0.100	0.050/0.100	0.050/0.100	0.050/0.100	0.050/0.100	0.050/0.100	0.075/0.150
	Final Pinionshaft	Taper Roller	0.050/0.100	0.050/0.100	-	-	-	-	-	-
		Parallel Roller	-	-	0.170	0.190	0.210	0.230	0.250	0.280
	Output Shaft (foot mounted)	Spherical Roller	1.000	1.000	1.000	0.250	0.300	0.300	0.340	0.400
	Output Shaft (shaft mounted)	Parallel Roller	0.140	0.155	0.170	0.190	0.210	0.230	0.250	0.280
H4	Input Shaft	Taper Roller	0.025/0.075	0.050/0.100	0.050/0.100	*	*	*	*	*
	2nd Pinionshaft	Taper Roller	0.025/0.075	0.050/0.100	0.050/0.100	*	*	*	*	*
	3rd Pinion Shaft	Taper Roller	0.050/0.100	0.050/0.100	0.050/0.100	*	*	*	*	*
	Final Pinionshaft	Taper Roller	0.050/0.100	0.050/0.100	-	*	*	*	*	*
		Parallel Roller	-	-	0.170	*	*	*	*	*
	Output Shaft (foot mounted)	Spherical Roller	1.000	1.000	1.000	*	*	*	*	*
	Output Shaft (shaft mounted)	Parallel Roller	0.140	0.155	0.170	*	*	*	*	*
B2	Input Shaft	Taper Roller	0.025/0.075	0.025/0.075	0.025/0.075	0.025/0.075	0.025/0.075	0.050/0.100	0.050/0.100	0.050/0.100
	2nd Reduction Pinionshaft	Taper Roller	0.050/0.100	0.050/0.100	0.050/0.100	0.050/0.100	0.050/0.100	0.050/0.100	0.075/0.125	0.075/0.150
	Output Shaft (foot mounted)	Spherical Roller	1.000	1.000	1.000	0.250	0.300	0.300	0.340	0.400
	Output Shaft (shaft mounted)	Parallel Roller	0.140	0.155	0.170	0.190	0.210	0.230	0.250	0.280
B3	Input Shaft	Taper Roller	0.025/0.075	0.025/0.075	0.025/0.075	0.025/0.075	0.025/0.075	0.025/0.075	0.050/0.100	0.050/0.100
	2nd Reduction Pinionshaft	Taper Roller	0.050/0.100	0.050/0.100	0.050/0.100	0.050/0.100	0.050/0.100	0.050/0.100	0.075/0.125	0.075/0.150
	Final Pinionshaft	Taper Roller	0.050/0.100	0.050/0.100	-	-	-	-	-	-
		Parallel Roller	-	-	0.170	0.190	0.210	0.230	0.250	0.280
	Output Shaft (foot mounted)	Spherical Roller	1.000	1.000	1.000	0.250	0.300	0.300	0.340	0.480
	Output Shaft (shaft mounted)	Parallel Roller	0.140	0.155	0.170	0.190	0.210	0.230	0.250	0.280
B4	Input Shaft	Taper Roller	0.025/0.075	0.025/0.075	0.025/0.075	*	*	*	*	*
	2nd Pinionshaft	Taper Roller	0.025/0.075	0.050/0.100	0.050/0.100	*	*	*	*	*
	3rd Pinionshaft	Taper Roller	0.050/0.100	0.050/0.100	0.050/0.100	*	*	*	*	*
	Final Pinionshaft	Taper Roller	0.050/0.100	0.050/0.100	-	*	*	*	*	*
		Parallel Roller	-	-	0.170	*	*	*	*	*
	Output Shaft (foot mounted)	Spherical Roller	1.000	1.000	1.000	*	*	*	*	*
	Output Shaft (shaft mounted)	Parallel Roller	0.140	0.155	0.170	*	*	*	*	*

Dimensions in mm
1mm = 0.039 inch

* Please contact our Application Engineers

SERIES H

APPENDIX 5

BEARINGS

0108

Method One (shafts other than bevel input shafts)

- 1) Assemble shaft, fitting covers and partially tightening the bolts then rotate shaft to ensure bearing rollers are correctly seated in their races.
- 2) When unit is completely assembled with top half of case in place, measure gaps between case and covers, at each side of case.
- 3) Add the two measurements together then add to it at least the minimum recommended end float but not more than the maximum see table. The total should then be divided by two so giving the value of shims for each cover.
- 4) Add shims and tighten bolts to torque values in table shown in Appendix 6.

Method Two (bevel input shaft only)

- 1) Assemble shaft, nipping locknut up against bearing but not fitting grub screw or oil catcher.
- 2) Check Tooth contact markings (see Appendix 7)
- 3) Set a dial indicator on shaft end so as to register any axial movement.
- 4) Slacken locknut gradually, pushing and pulling shaft each time it is moved to check movement registered on dial indicator.
- 5) On reaching a point where movement registered is within the bearing end float tolerance (see table) fit grub screw so locking locknut in place.

Type of Unit	Shaft	Type of Bearing	Size of Unit							
			355 min/max	400 min/max	450 min/max	500 min/max	560 min/max	630 min/max	710 min/max	800 min/max
H1	Input Shaft	Taper Roller	0.075/0.175	0.340 ●	0.380 ●	1.000 ●	-	-	-	-
	Output Shaft	Spherical Roller	0.400	0.480	0.560	1.000	-	-	-	-
H2	Input Shaft	Taper Roller	0.075/0.150	0.100/0.175	0.125/0.200	0.125/0.200	0.175/0.250	0.200/0.275	0.200/0.275	-
	2nd Reduction Pinionshaft	Taper Roller	-	-	-	-	-	-	-	-
		Parallel Roller	0.310	0.340	0.390	0.500	0.500	0.750	0.750	-
	Output Shaft (foot mounted)	Spherical Roller	0.400	0.480	0.560	1.000	1.250	1.250	1.500	-
Output Shaft (shaft mounted)	Parallel Roller	0.310	0.340	0.390	0.500	0.500	0.750	0.750	-	
H3	Input Shaft	Taper Roller	0.075/0.150	0.100/0.175	0.100/0.175	0.100/0.175	0.125/0.200	0.175/0.250	0.200/0.275	0.200/0.275
	2nd Reduction Pinionshaft	Taper Roller	0.075/0.150	0.100/0.175	0.100/0.175	0.100/0.175	0.125/0.200	0.175/0.250	0.200/0.275	0.200/0.275
	Final Pinionshaft	Taper Roller	-	-	-	-	-	-	-	-
		Parallel Roller	0.310	0.340	0.390	0.500	0.500	0.750	0.750	0.750
	Output Shaft (foot mounted)	Spherical Roller	0.400	0.480	0.560	1.000	1.250	1.250	1.500	1.500
	Output Shaft (shaft mounted)	Parallel Roller	0.310	0.340	0.390	0.500	0.500	0.750	0.750	0.750
H4	Input Shaft	Taper Roller	*	*	*	*	*	*	*	*
	2nd Pinionshaft	Taper Roller	*	*	*	*	*	*	*	*
	3rd Pinion Shaft	Taper Roller	*	*	*	*	*	*	*	*
	Final Pinionshaft	Taper Roller	*	*	*	*	*	*	*	*
		Parallel Roller	*	*	*	*	*	*	*	*
	Output Shaft (foot mounted)	Spherical Roller	*	*	*	*	*	*	*	*
	Output Shaft (shaft mounted)	Parallel Roller	*	*	*	*	*	*	*	*
B2	Input Shaft	Taper Roller	0.075/0.125	0.075/0.125	0.075/0.150	0.100/0.175	-	-	-	-
	2nd Reduction Pinionshaft	Taper Roller	0.100/0.175	0.125/0.200	0.125/0.200	0.125/0.200	-	-	-	-
	Output Shaft (foot mounted)	Spherical Roller	0.400	0.480	0.560	1.000	-	-	-	-
	Output Shaft (shaft mounted)	Parallel Roller	0.310	0.340	0.390	0.500	-	-	-	-
B3	Input Shaft	Taper Roller	0.075/0.125	0.075/0.125	0.075/0.125	0.075/0.125	0.075/0.125	0.100/0.175	0.100/0.175	-
	2nd Reduction Pinionshaft	Taper Roller	0.075/0.175	0.100/0.175	0.100/0.175	0.100/0.175	0.125/0.200	0.125/0.200	0.125/0.200	-
	Final Pinionshaft	Taper Roller	-	-	-	-	-	-	-	-
		Parallel Roller	0.310	0.340	0.390	0.500	0.500	0.750	0.750	-
	Output Shaft (foot mounted)	Spherical Roller	0.400	0.480	0.560	1.000	1.250	1.250	1.500	-
	Output Shaft (shaft mounted)	Parallel Roller	0.310	0.340	0.390	0.500	0.500	0.750	0.750	-
B4	Input Shaft	Taper Roller	*	*	*	*	*	*	*	*
	2nd Pinionshaft	Taper Roller	*	*	*	*	*	*	*	*
	3rd Pinionshaft	Taper Roller	*	*	*	*	*	*	*	*
	Final Pinionshaft	Taper Roller	*	*	*	*	*	*	*	*
		Parallel Roller	*	*	*	*	*	*	*	*
	Output Shaft (foot mounted)	Spherical Roller	*	*	*	*	*	*	*	*
	Output Shaft (shaft mounted)	Parallel Roller	*	*	*	*	*	*	*	*

Dimensions in mm
1mm = 0.039 inch

* Please contact our Applications Engineers
● Spherical Roller

SERIES H

APPENDIX 6

TIGHTENING TORQUES

0108

TIGHTENING TORQUES FOR CASE JOINT STUDS, COVER AND HOUSING BOLTS

Standard Units are now fitted with joint studs secured with plain nuts and Loctite

Units were previously supplied fitted with Joint Studs secured with Nyloc nuts

Alternative tightening torques are shown for plain nuts and Nyloc nuts. Nuts should be tightened to the correct torque during routine maintenance

Unit Size	Unit Type	Case Joint Studs fitted with Nyloc Nuts			Case Joint Studs fitted with Plain Nuts and Loctite			Cover and Housing Bolts		
		Thread Size	Torque Nm	Torque lbf-in	Thread Size	Torque Nm	Torque lbf-in	Thread Size	Torque Nm	Torque lbf-in
140	H1 and B2	-	-	-	M10	45	400	M8	25	220
		-	-	-	-	-	-	M10	50	440
	H2 and B3	-	-	-	M10	45	400	M8	25	220
		-	-	-	-	-	-	M10	50	440
160	H1 and B2	-	-	-	M10	45	400	M8	25	220
		-	-	-	-	-	-	M10	50	440
	H2 and B3	-	-	-	M12	77	680	M8	25	220
		-	-	-	M10	45	400	M10	50	440
180	H1 and B2	-	-	-	M10	45	400	M8	25	220
		-	-	-	M12	77	680	M10	50	440
	H2 and B3	-	-	-	M16	180	1600	-	-	-
		-	-	-	M10	45	400	M8	25	220
200	H1 and B2	M12	85	750	M12	45	400	M8	25	220
		M16	220	1950	M16	180	1600	M10	50	440
	H2, H3 and B3	M12	85	750	M12	45	400	M8	25	220
		M16	220	1950	M16	180	1600	M10	50	440
225	H1 and B2	M12	85	750	M12	77	680	M10	50	440
		M16	220	1950	M16	180	1600	M12	85	750
	H2, H3 and B3	M20	440	3890	M20	315	2790	-	-	-
		M12	85	750	M12	77	680	M8	25	220
250	H1 and B2	M16	220	1950	M16	180	1600	M10	50	440
		M20	440	3890	M20	315	2790	M12	85	750
	H2, H3 and B3	M16	220	1950	M16	180	1600	M8	25	220
		M20	440	3890	M20	315	2790	M10	50	440
280	H1 and B2	M16	220	1950	M16	180	1600	M10	50	440
		M20	440	3890	M20	315	2790	M12	85	750
	H2, H3 and B3	M24	760	6730	M24	550	4870	-	-	-
		M16	220	1950	M16	180	1600	M8	25	220
315	H1 and B2	M20	440	3890	M20	315	2790	M10	50	440
		M24	760	6730	M24	550	4870	M12	85	750
	H2, H3 and B3	M27-M24	760	6730	M27-M24	550	4870	M16	200	1770
		M20	440	3890	M20	315	2790	M10	50	440
355	H1 and B2	M24	760	6730	M24	550	4870	M12	85	750
		M30	1520	13450	M30	1100	9740	M16	200	1770
	H2, H3 and B3	M20	440	3890	M20	315	2790	M10	50	440
		M24	760	6730	M24	550	4870	M12	85	750
400	H1 and B2	M30	1520	13450	M30	1100	9740	M16	200	1770
		M24	760	6730	M24	550	4870	M12	85	750
	H2, H3 and B3	M30	1520	13450	M30	1100	9740	M20	350	3100
		M24	760	6730	M24	550	4870	M12	85	750
450	H1 and B2	M36	2690	23800	M36	1950	17260	-	-	-
		M30	1520	13450	M30	1100	9740	M20	350	3100
	H2, H3 and B3	M24	760	6730	M24	550	4870	M12	85	750
		M30	1520	13450	M30	1100	9740	M16	200	1770

Refer to Applications Engineers for sizes 500 and above

0108

Series H units are fitted with either single helical gears throughout or a combination of single helical and spiral bevel gears. The helical gears are case hardened and profile ground, the spiral bevel gears are lapped in pairs, all to give the highest standards of accuracy and finish while giving it its quiet running characteristics.

TOOTH CONTACT (Spiral Bevels)

In the event of gears being disturbed it will be necessary to check the tooth contact of the bevel gears if fitted, see recommended procedure laid out below.

- 1) Assemble unit including fitting the top half of case but without input shaft.
- 2) Assemble bearing housing assembly nipping locknut up against bearing but do not fit grub screw.
- 3) Fit bearing housing assembly to case without shim, ensuring that the back faces of the mating gears are flush with each other.

Note: Gears may be observed through inspection hole.

- 4) There should at this point be a gap between bearing housing and case, this gap should be measured and shims added equal to it.

Note: Operations 3 and 4 may be ignored if same gears are being refitted in this case the old shims or new ones equivalent to them may be fitted.

- 5) Bolt bearing housing to case tightening bolts to torque values in table in Appendix 6
- 6) Using inspection hole to reach it, apply engineers blue to both flanks of pinion teeth.
- 7) Rotate gears slowly until a well defined contact marking has been produced on the wheel.
- 8) Compare tooth markings with diagrams below.
- 9) If tooth markings are not as in first diagram remove bearing housing and:-
 - a) add more shims if marking are as in second diagram.
 - b) reduce shimming if markings are in third diagram.
- 10) Repeat operations as from number 5.

Note: After attaining the correct tooth marking the backlash should be checked (see table below).

If backlash is excessive both bevels gears should be adjusted towards their apexes by adjusting the shims accordingly. Adjustment in the opposite direction will increase backlash in the bevel gears.

Correct Marking

Pinion member left hand in all cases shown

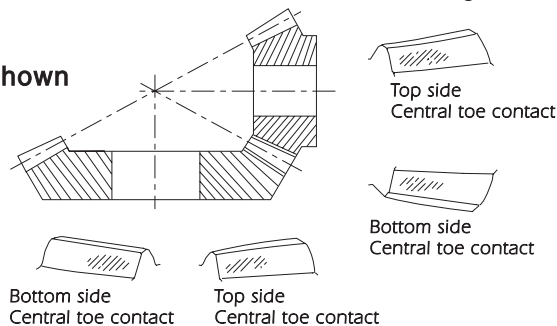

Incorrect Marking Move pinion out

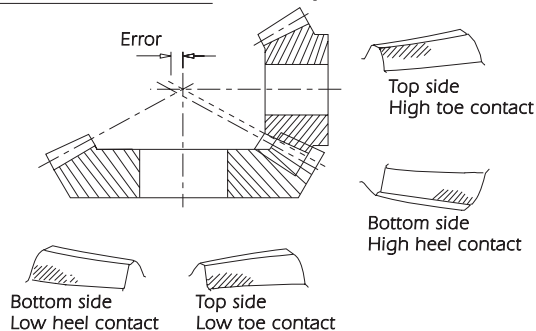

Incorrect Marking Move pinion in

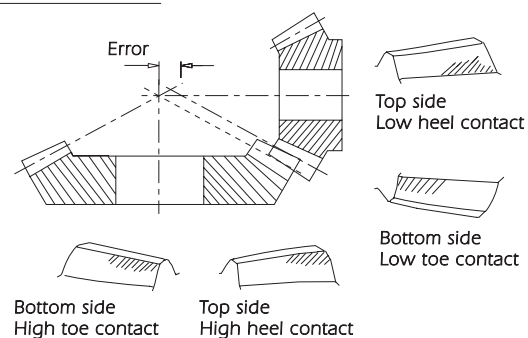

Table of Normal Backlash (Spiral Bevels)

	UNIT SIZE						
	B3/140,160,180 B4/140,160,180	B2/140,160 B3/200,225	B2/180,200 B3/250,280	B2/225,250 B3/315,355	B2/280,315 B3/400,450	B2/355,400 B3/500, 560	B2/450, 500 B3/630, 710
mm	0.05 - 0.10	0.08 - 0.13	0.10 - 0.15	0.13 - 0.18	0.15 - 0.20	0.20 - 0.28	0.28 - 0.38
Inches	0.002 - 0.004	0.003 - 0.005	0.004 - 0.006	0.005 - 0.007	0.006 - 0.008	0.008 - 0.011	0.011 - 0.015

SERIES H

NOTES

SERIES H

Contact Details

0108

AUSTRALIA

David Brown Gear Industries Ltd
13-19 Franklin Avenue
Bulli, NSW 2516
Australia
Tel: +61 2 4283 0300
Fax: +61 2 4283 0333

AUSTRIA

Benzler Antriebstechnik Ges mbH
Urnenhainweg 7
AT-4050 Traun
Austria
Tel: +43 7 229 618 91
Fax: +43 7 229 618 84

BELGIUM

Benzlers Belgium
Contact the Northern European Service Centre (Netherlands)
Tel: +32 25 82 59 22
Fax: +32 25 82 68 47

CANADA

David Brown Radicon Inc
975 Dillingham Road
Pickering, Ontario
L1W 3B2
Canada
Tel: +01 905 420 4141
Fax: +01 905 420 9513

DENMARK

Benzler Transmission A/S
Hammerholmen 39
DK-2650 Hvidovre
Denmark
Tel: +45 36 34 03 00
Fax: +45 36 77 02 42

FINLAND

Oy Benzler AB
PB 3
FI 02211 Espoo
Finland
Tel: +358 9 8870 630
Fax: +358 9 8870 631

FRANCE

Benzler France
Contact the Northern European Service Centre (Netherlands)
Tel: +33 130 32 79 00
Fax: +33 130 32 80 40

David Brown Transmissions France SA

42 Avenue du Progrès, BP 149
69686 Chassieu Cedex
France
Tel: +33 4 72 47 61 50
Fax: +33 4 72 47 61 69

DSN

9 rue de la Verrerie, BP 135
ZI Le Fontanil Cedex
38521 El Fontanil
France
Tel: +33 4 76 75 66 83
Fax: +33 4 76 75 57 99

WECO

33 Rue Henri-Lebert, BP 48
68801 Thann Cedex
France
Tel: +33 3 89 37 01 13
Fax: +33 3 89 37 39 36

GERMANY

Benzler Germany
Contact the Northern European Service Centre (Netherlands)
Tel: 0800 350 40 00
Fax: 0800 350 40 01

HUNGARY

Benzler Antriebstechnik Ges mbH
Urnenhainweg 7
AT-4050 Traun
Austria
Tel: +43 7 229 618 91
Fax: +43 7 229 618 84

ITALY

Benzler Ferri SpA
Via F.lli Rosselli 16
IT 42019 Scandiano (RE)
Italy
Tel: +39 05 22 763314
Fax: +39 05 22 981758

MALAYSIA

Benzler (M) Sdn Bhd
No 24 Jalan TPJ 3
Taman Perindustrian
Jaya Subang
MY 47200 Selangor
Malaysia
Tel: +60 3 745 0668
Fax: +60 3 746 1436

NETHERLANDS

Northern European Service Centre & HQ Benzlers Netherland
Postbox 3303
NL 5902 Venlo RH
Netherlands
Tel: +31 773 245 900
Fax: +31 773 245 901

NORWAY

Textron Power Transmission (Norge)
Incorporating Benzler A/S & David Brown Hydraulics Norway A/S
PO Box 73 Leirdal
Stromsveien 372
NO- 1008 Oslo
Norway
Tel: +47 22 90 94 30
Fax: +47 22 90 94 11

PHILIPPINES

David Brown John Welsh Custom Build (Pty) Ltd
Unit 1207 One Magnificent Mile
San Miguel Ave, Ortigas Centre
Pasig City, Philippines
Tel: +63 6 32 910 0316
Fax: +63 6 32 910 0317

SINGAPORE

Benzler (FE) Pte Ltd
1 Clementi Loop
#03-08
Singapore 129808
Tel: +65 469 0777
Fax: +65 469 2083

SOUTH AFRICA

David Brown Gear Industries Ltd
PO Box 540, Benoni 1500
South Africa
Tel: +27 11 748 0000
Fax: +27 11 421 2963

David Brown Gear Industries Ltd
PO Box 36882
Chempet 7442
Cape Town
South Africa
Tel: +27 21 551 2163
Fax: +27 21 551 2164

David Brown Gear Industries Ltd
Natal Sales Office
39 Richmond Road
Pinetown 3600
Natal, South Africa
Tel: +27 31 700 3302
Fax: +27 31 700 1872

SWEDEN

AB Benzlers
PO Box 922
SE-251 09 Helsingborg
Sweden
Tel: +46 42 18 6800
Fax: +46 42 21 8803

THAILAND

David Brown Powauto (Thailand) Ltd
Level 5 Sermsrap Building
169/98 Ratchadapisek Road
Din Daeng, Bangkok 10320
Thailand
Tel: +66 2 276 9504/5/6
Fax: +66 2 276 9503

UNITED KINGDOM

Textron Power Transmission Corporate HQ
Park Road
Lockwood, Huddersfield
West Yorkshire. HD4 5DD
Tel: +44 (0) 1484 465500
Fax: +44 (0) 1484 465501

David Brown Engineering Ltd
Park Road
Lockwood, Huddersfield
West Yorkshire. HD4 5DD
Sales
Tel: 0800 970 4001
Fax: 0800 970 4002
Service & Spare Parts
Tel: 0800 970 4003
Fax: 0800 970 4004

USA

Cone Drive Textron
240 East 12th Street
Traverse City
MI 49684
USA
Tel: +01 231 946 8410
Fax: +01 231 933 8600

AGRICULTURE

ENERGY

PULP & PAPER

AUTOMOTIVE

FOOD & BEVERAGE

QUARRYING

CEMENT

FORESTRY

RUBBER & PLASTICS

CHEMICAL

MARINE

TEXTILES

CONSTRUCTION

METALS

TRANSPORTATION

DEFENCE

MINING

WATER

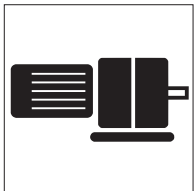

Geared motors

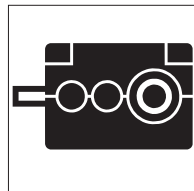

Industrial reducers

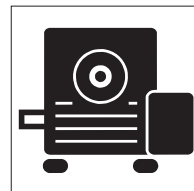

Worm

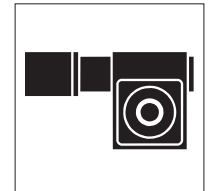

Precision products

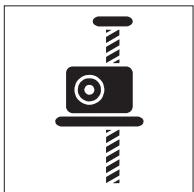

Screwjacks

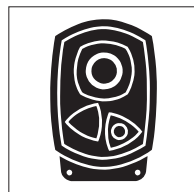

Shaftmount

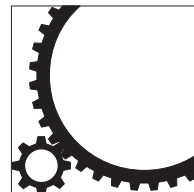

Horizontal mill drives

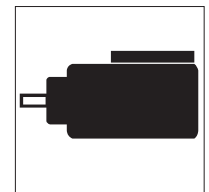

Vertical mill drives

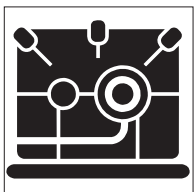

High speed

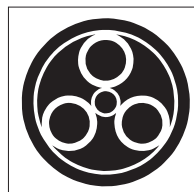

Planetary units

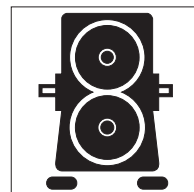

Specialist drives

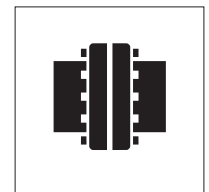

Couplings



Defence Systems

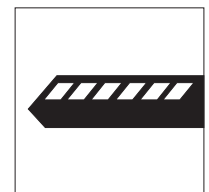
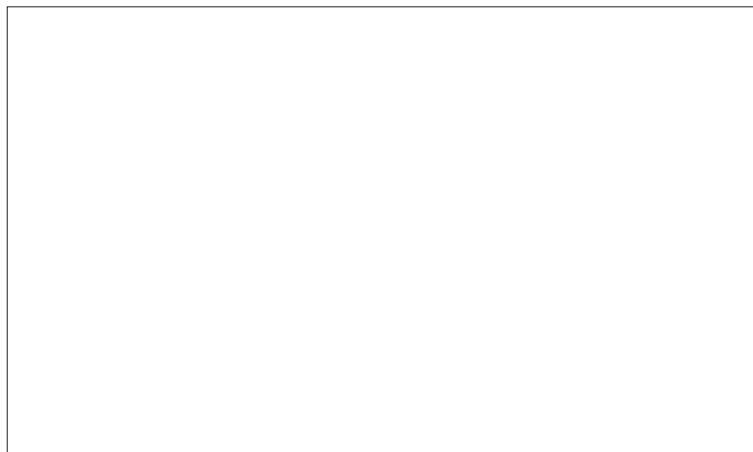

Rail